

Reducing Flange Type 1

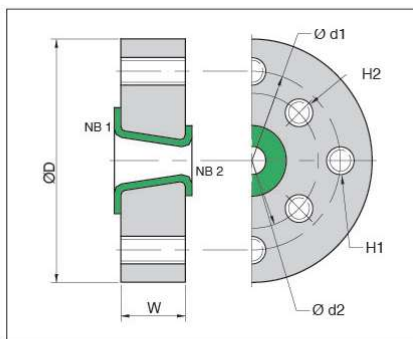

Reducing Flange Type 2

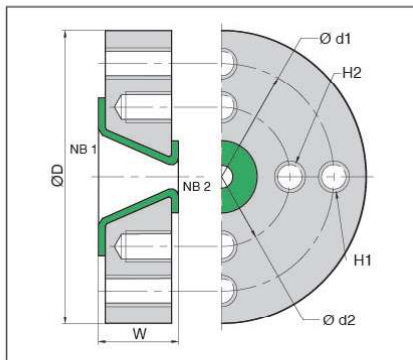

Reducing Flange Type 3

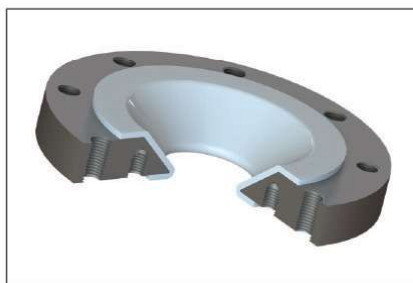

NB1 # 150	NB2 # 150	D mm	W mm	d1 mm	H1 UNC/mm	d2 mm	H2 UNC/mm	Type	Wt Kg
3/4"	1/2"	98	35	69.8	4x1/2" UNC	60.3	4x1/2" UNC	2	1.9
1"	1/2"	108	35	79.4	4x1/2" UNC	60.3	4x1/2" UNC	2	2.1
	3/4"	108	35	79.4	4x1/2" UNC	69.8	4x1/2" UNC	2	2.0
1 1/2"	1/2"	127	35	98.4	4x1/2" UNC	60.3	4x1/2" UNC	3	4.1
	3/4"	127	35	98.4	4x1/2" UNC	69.8	4x1/2" UNC	3	4.0
	1"	127	35	98.4	4x1/2" UNC	79.4	4x1/2" UNC	2	3.9
2"	1/2"	152	35	120.6	4x5/8" UNC	60.3	4x1/2" UNC	3	4.8
	3/4"	152	35	120.6	4x5/8" UNC	69.8	4x1/2" UNC	3	4.8
	1"	152	35	120.6	4x5/8" UNC	79.4	4x1/2" UNC	3	4.7
	1 1/2"	152	35	120.6	4x5/8" UNC	98.4	4x1/2" UNC	2	4.5
3"	1/2"	190	35	152.4	4x19 mm	60.3	4x1/2" UNC	1	6.7
	3/4"	190	35	152.4	4x19 mm	69.8	4x1/2" UNC	1	6.6
	1"	190	35	152.4	4x19 mm	79.4	4x1/2" UNC	1	6.5
	1 1/2"	190	35	152.4	4x5/8" UNC	98.4	4x1/2" UNC	3	6.2
4"	2"	190	35	152.4	4x5/8" UNC	120.6	4x5/8" UNC	2	6.0
	1/2"	229	45	190.5	8x19 mm	60.3	4x1/2" UNC	1	11
	3/4"	229	45	190.5	8x19 mm	69.8	4x1/2" UNC	1	11
	1"	229	45	190.5	8x19 mm	79.4	4x1/2" UNC	1	11
	1 1/2"	229	45	190.5	8x19 mm	98.4	4x1/2" UNC	1	11
6"	2"	229	45	190.5	8x5/8" UNC	120.6	4x5/8" UNC	3	10
	3"	229	45	190.5	8x5/8" UNC	152.4	4x5/8" UNC	3	10
	1"	279	45	241.3	8x22 mm	79.4	4x1/2" UNC	1	17
	1 1/2"	279	45	241.3	8x22 mm	98.4	4x1/2" UNC	1	17
	2"	279	45	241.3	8x22 mm	120.6	4x5/8" UNC	1	17
8"	3"	279	45	241.3	8x3/4" UNC	152.4	4x5/8" UNC	3	16
	4"	279	45	241.3	8x3/4" UNC	190.5	8x5/8" UNC	2	15
	1"	343	45	298.4	8x22 mm	79.4	4x1/2" UNC	1	25
	1 1/2"	343	45	298.4	8x22 mm	98.4	4x1/2" UNC	1	25
	2"	343	45	298.4	8x22 mm	120.6	4x5/8" UNC	1	25
10"	3"	343	45	298.4	8x22 mm	152.4	4x5/8" UNC	1	24
	4"	343	45	298.4	8x22 mm	190.5	8x5/8" UNC	1	23
	6"	343	45	298.4	8x3/4" UNC	241.3	8x3/4" UNC	3	20
	1 1/2"	406	45	362.0	12x25.5 mm	98.4	4x1/2" UNC	1	34
	2"	406	45	362.0	12x25.5 mm	120.6	4x1/2" UNC	1	34
	3"	406	45	362.0	12x25.5 mm	152.4	4x1/2" UNC	1	33
12"	4"	406	45	362.0	12x25.5 mm	190.5	8x5/8" UNC	1	33
	6"	406	45	362.0	12x25.5 mm	241.3	8x3/4" UNC	1	30
	8"	406	45	362.0	12x7/8" UNC	298.4	8x3/4" UNC	3	27
	2"	483	50	431.8	12x25.5 mm	120.6	4x1/2" UNC	1	55
	3"	483	50	431.8	12x25.5 mm	152.4	4x1/2" UNC	1	54
	4"	483	50	431.8	12x25.5 mm	190.5	8x5/8" UNC	1	54
12"	6"	483	50	431.8	12x25.5 mm	241.3	8x3/4" UNC	1	49
	8"	483	50	431.8	12x25.5 mm	298.4	8x3/4" UNC	1	44
	10"	483	50	431.8	12x7/8" UNC	361.9	12x7/8" UNC	3	43

STEEL	SIZE	MATERIAL	STANDARDS	NOTE
RED FLGS	1" - 12"	Carbon Steel	AB-EH36 / ST52-3 / ASTM A106 Gr B / API 5L	Drilled Bolt Holes

Stainless steel / other material on request.